

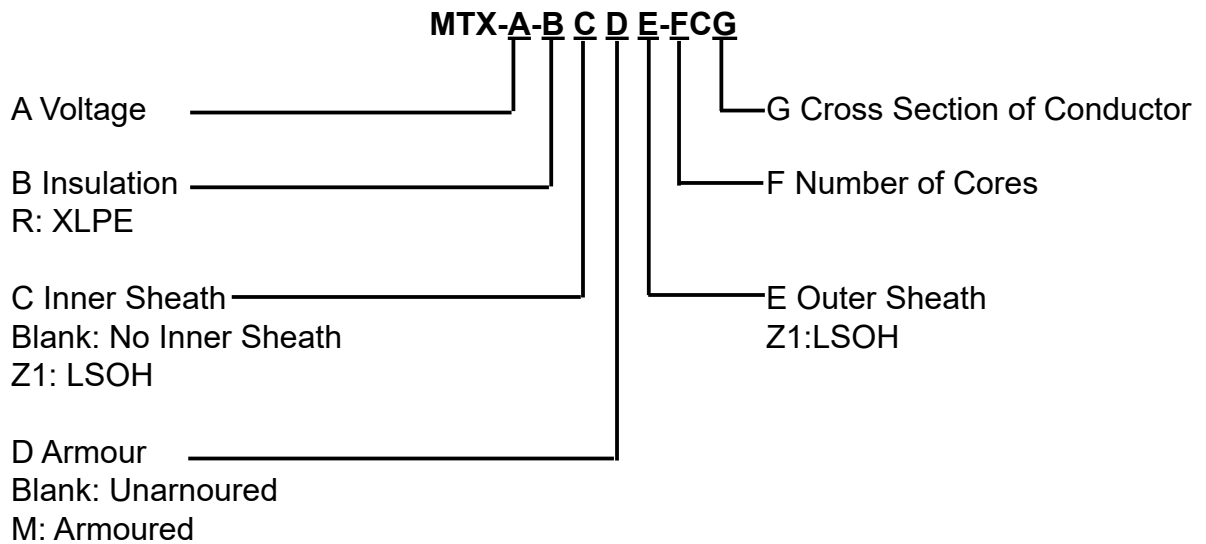

### Caledonian Order Code

### MariTox Marine Flame Retardant Medium Voltage Cables



### MariTox Marine Flame Retardant Power & Control Cables

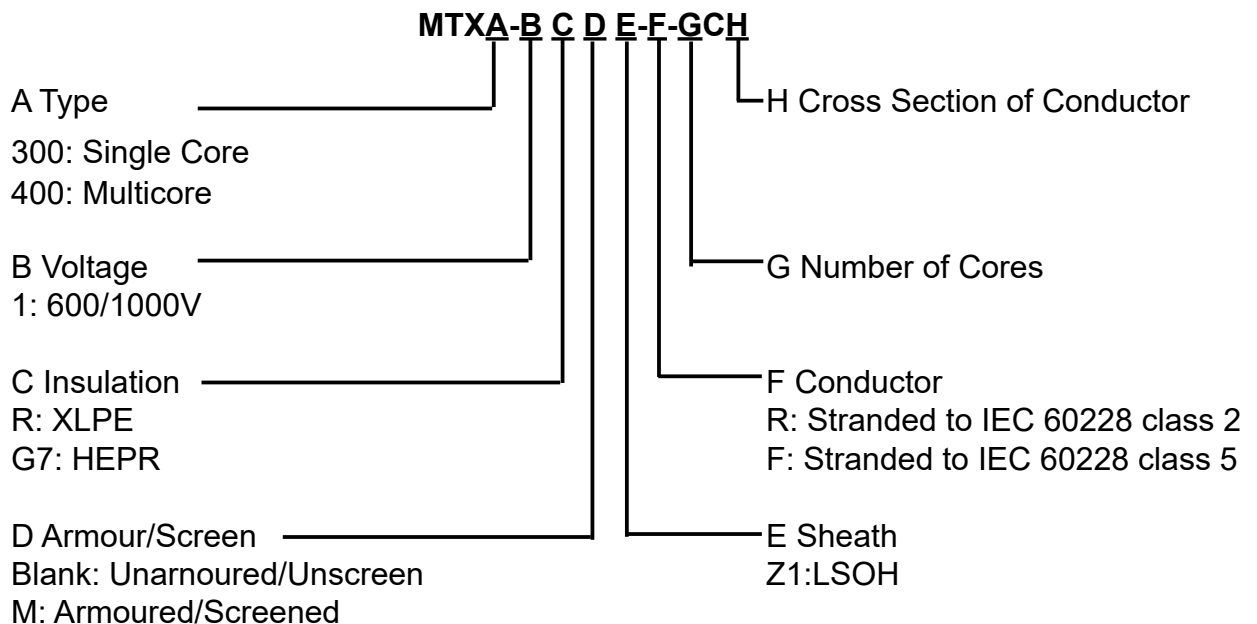



### MariFlex Marine Fire Resistant Power & Control Cables

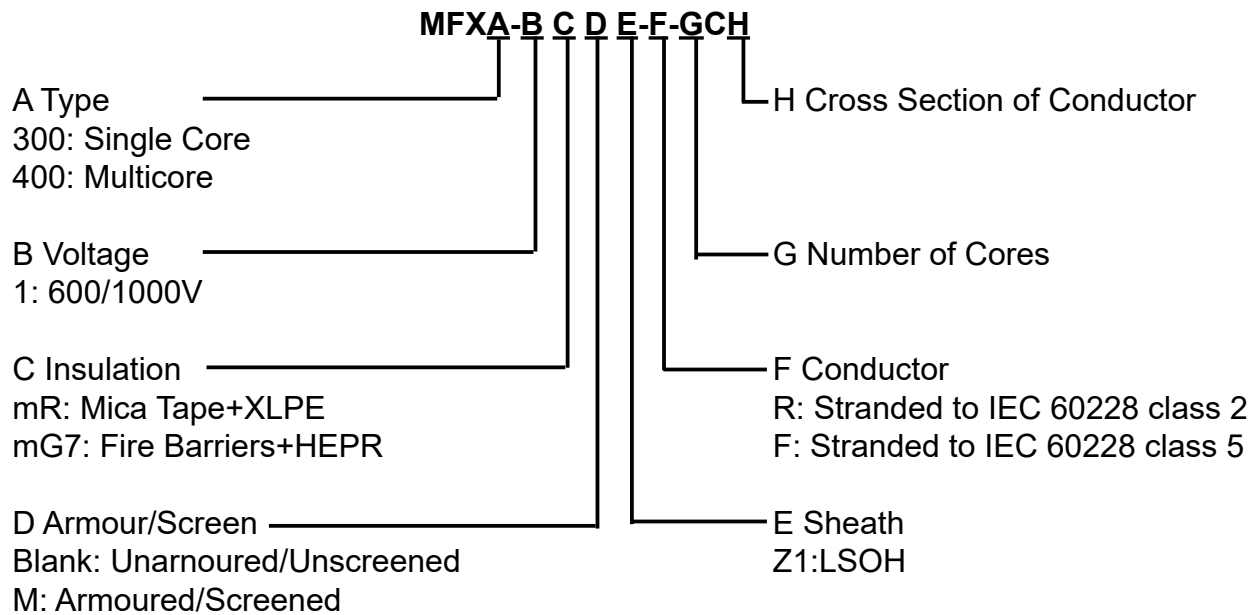

### MariSig Flame Retardant Instrumentation & Control Cables

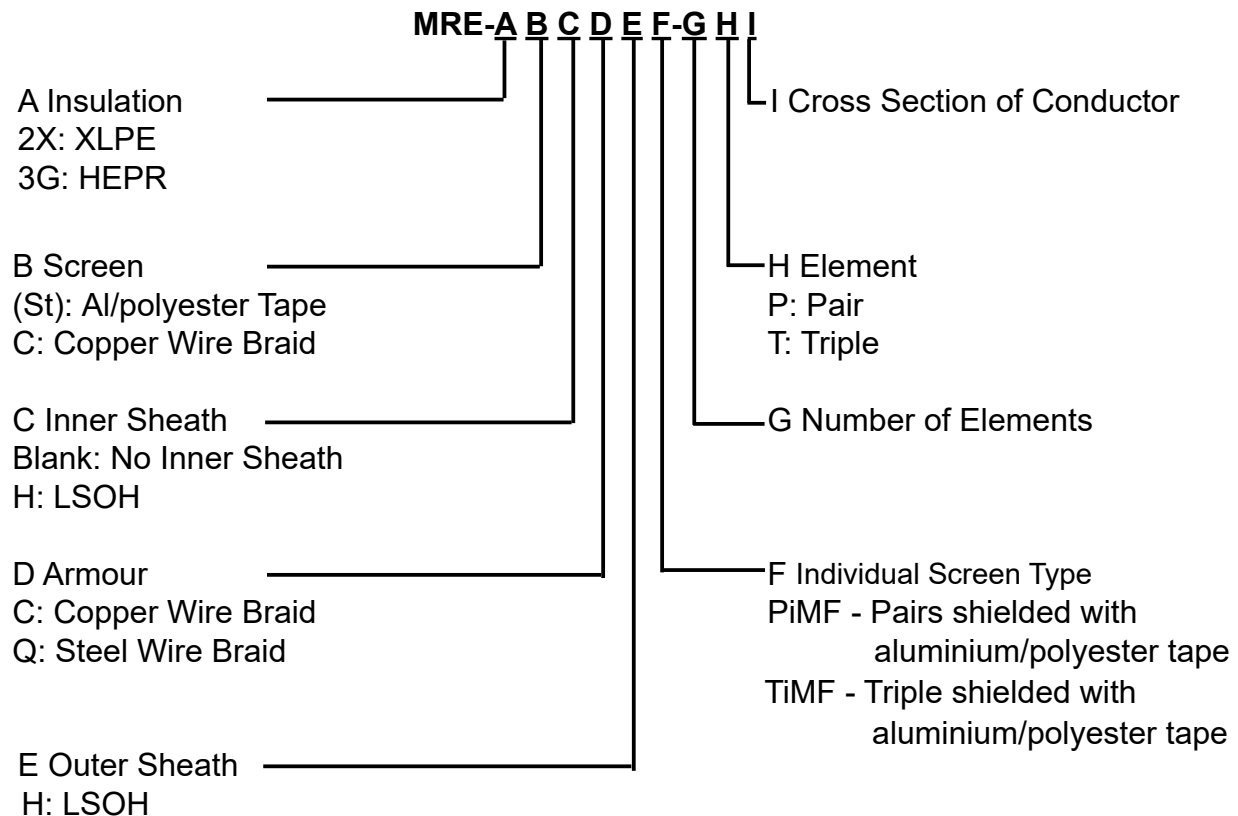



## Technical Information

www.caledonian-cables.co.uk

### MariSig Fire Resistant Instrumentation & Control Cables

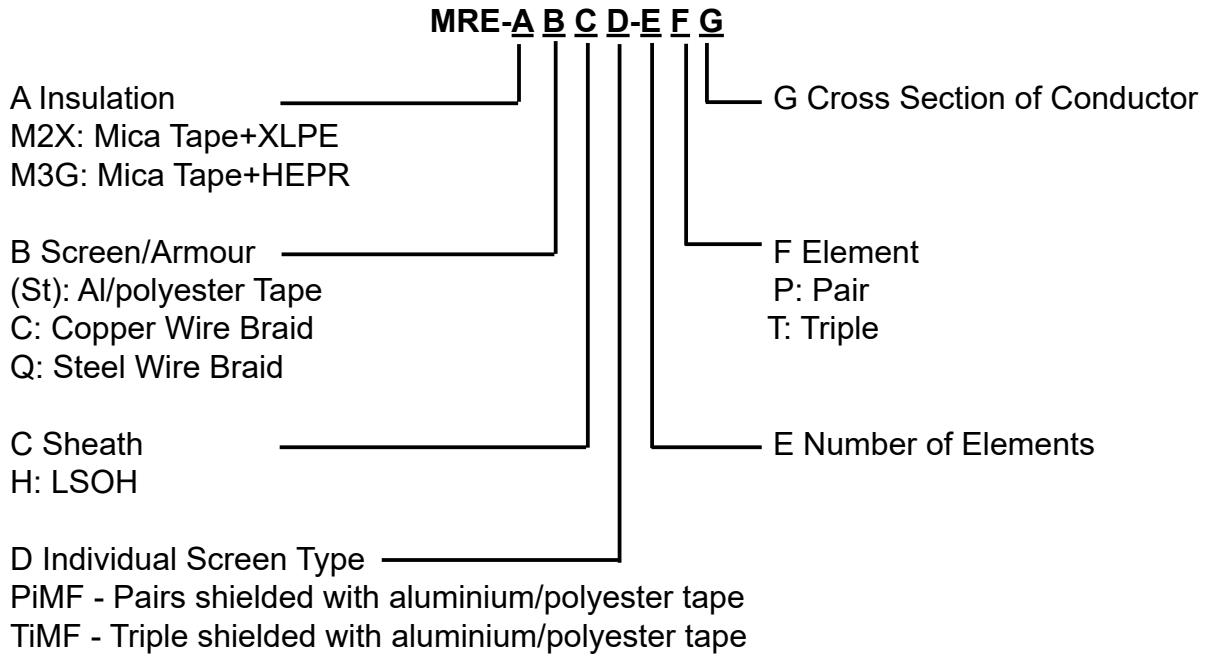

### MariLan Marine Lan Data & Communication Cables

#### LAN CABLE

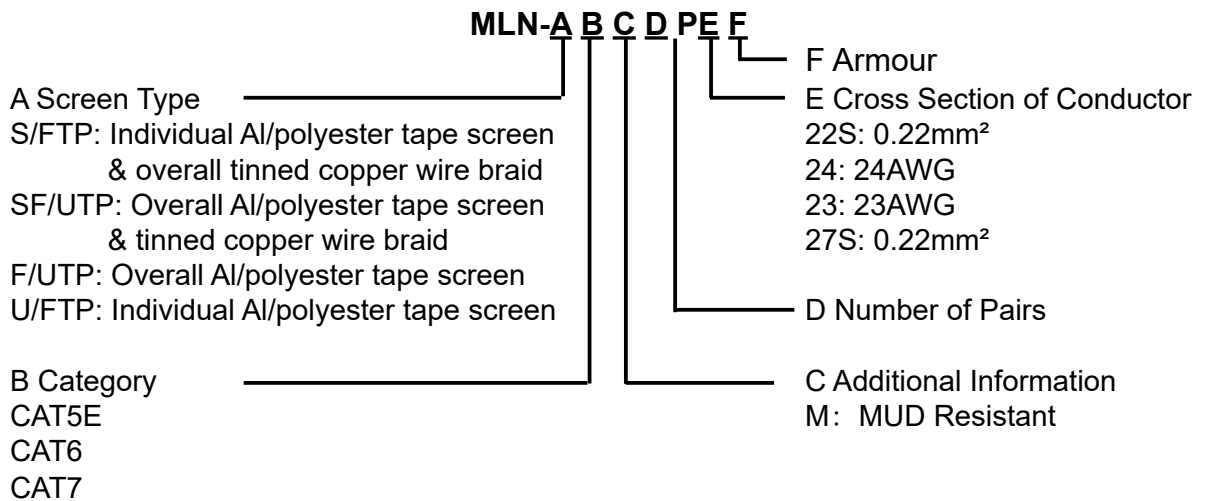

#### COAXIAL CABLE



#### BUS CABLE



### MLN-A B C D E F-G × 2 × H

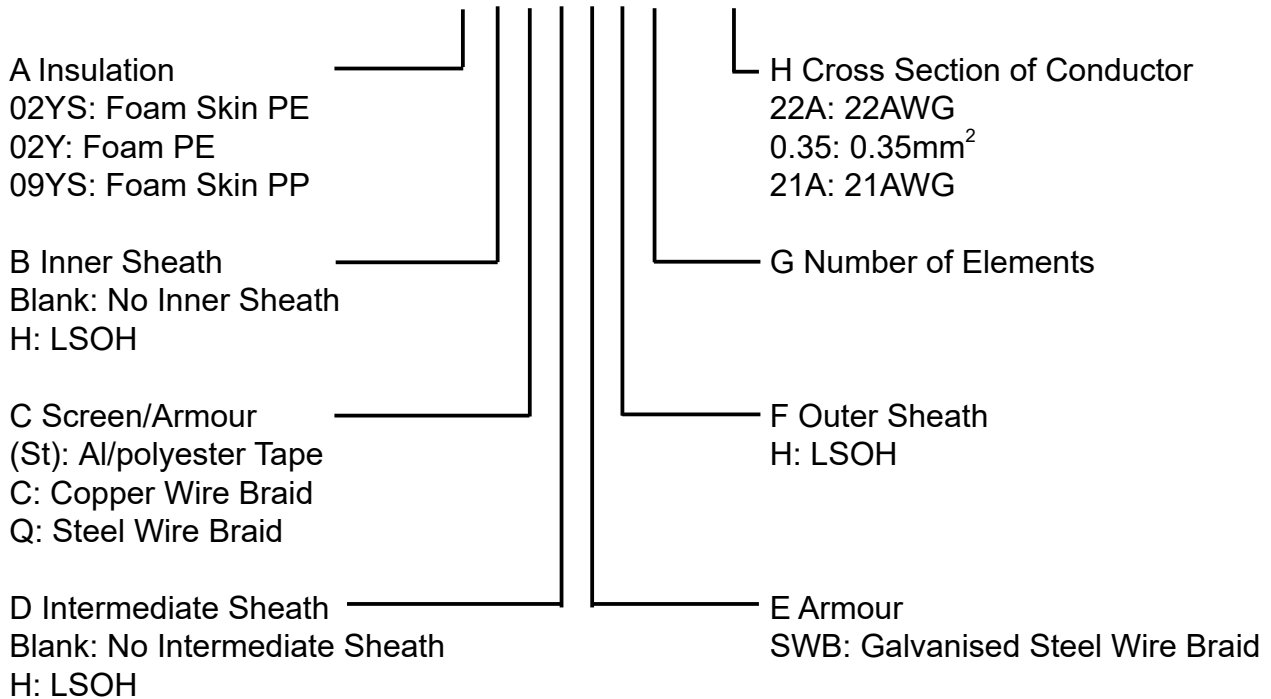

### OPTICAL FIBER CABLE

#### MLN-BTA-X-N-H-F-H-CD-A

Semi-tight buffered (CD) breakout cable (BT) with halogen free & flame-retardant subcable sheath (H), FRP central member (F), SHF1 sheath (H) and aramid strain relief elements.

#### MLN-MTA-X-N-H-F-H-CD/VT-A

Semi tight buffered (CD) or tight buffered (VT) distribution cable (MT) with halogen free & flame-retardant subcable sheath (H), FRP central member (F), SHF1 sheath (H) and aramid strain relief elements.

#### MLN-MTA-X-N-H-VT-G

Tight buffered (VT) distribution cable (MT) with LSOH & FR compound sheath (H) and fiberglass yarn reinforcing elements (G).

#### MLN-CLA-X-N-H-J-G

Central loose tube cable (CL) with water blocking gel in tubes (J), LSOH & FR compound sheath (H) and fiberglass yarn reinforcing elements (G).

#### MLN-FCLA-X-N-H-J

Fire resistant (F) central loose tube cable (CL) with water blocking gel in tubes (J) and SHF1 sheath (H).

X: Fiber type (0=Fiber and copper conductors in cable 4=50/125 multi-mode fiber (OM3); 5=50/125 multi-mode fiber (OM2); 6=50/125 multi-mode fiber (OM1); 7=NZDS SM fiber per G.656.; 8=NZDS SM fiber per G.655.; 9=Standard SM fiber per G.652.D). N: No. of Fibers.



### Power Copper Conductors According to IEC 60228

#### Tinned conductors

Cross section	cl.2	cl.5	Cross section	cl.2	cl.5
mm <sup>2</sup>	Ohm/km	Ohm/km	mm <sup>2</sup>	Ohm/km	Ohm/km
1.0	18.2	20	70	0.270	0.277
1.5	12.2	13.7	95	0.195	0.210
2.5	7.56	8.21	120	0.154	0.164
4	4.70	5.09	150	0.126	0.132
6	3.11	3.39	185	0.100	0.108
10	1.84	1.95	240	0.0762	0.0817
16	1.16	1.24	300	0.0607	0.0654
25	0.734	0.795	400	0.0475	0.0495
35	0.529	0.565	500	0.0369	0.0391
50	0.391	0.393	630	0.0286	0.0292

#### Plain conductors

Cross section	cl.2	cl.5	Cross section	cl.2	cl.5
mm <sup>2</sup>	Ohm/km	Ohm/km	mm <sup>2</sup>	Ohm/km	Ohm/km
1	18.1	19.5	70	0.268	0.272
1.5	12.1	13.3	95	0.193	0.206
2.5	7.41	7.98	120	0.153	0.161
4	4.61	4.95	150	0.124	0.129
6	3.08	3.30	185	0.0991	0.106
10	1.83	1.91	240	0.0754	0.0801
16	1.15	1.21	300	0.0601	0.0641
25	0.727	0.780	400	0.0470	0.0486
35	0.524	0.554	500	0.0366	0.0384
50	0.387	0.386	630	0.0283	0.0287



### Correction factors according to IEC 60228

IEC 60228 standard provides electrical resistance of copper conductors at an ambient temperature of 20° C.

For other temperatures, correction factors are applied as below:

Temperature (°C)	Kt
5	1.064
10	1.042
15	1.020
20	1.000
25	0.980
30	0.962
35	0.943
40	0.926
45	0.909
50	0.893
55	0.877
60	0.862
65	0.847
70	0.833
75	0.820
80	0.806
85	0.794
90	0.781
95	0.769
100	0.758

### Instrumentation & Control Conductors According to IEC 60092-

### 376

Cross section mm <sup>2</sup>	Tinned conductors		Plain conductors	
	cl.2 Ohm/km	cl.5 Ohm/km	cl.2 Ohm/km	cl.5 Ohm/km
0.5	41.6	42.5	40.4	41.4
0.75	26.3	28.3	26.0	27.6
1	19.3	21.2	19.2	20.7
1.5	12.9	14.5	12.8	14.1
2.5	8.02	8.71	7.56	8.47



### Current Ratings for Continuous Service (IEC 60092-352)

Conductor temperature Nominal cross-sectional Area (mm <sup>2</sup> )	90°C					
	Single core (A)		Two core (A)		Three core & four core (A)	
0.5	10		8.5		7	
0.75	13		11		9	
1	18		15		13	
1.5	23		20		16	
2.5	30		26		21	
4	40		34		28	
6	52		44		36	
10	72		61		50	
16	96		82		67	
25	127		108		89	
35	157		133		110	
50	196		167		137	
70	242		206		169	
95	293		249		205	
120	339		288		237	
150	389		331		273	
185	444		377		311	
240	522		444		366	
300	601		511		420	
	d.c.	a.c.	d.c.	a.c.	d.c.	a.c.
400	690	670	587	570	483	469
500	780	720	663	612	546	504
500	890	780	757	663	623	546

#### Note

1. Maximum permissible service temperature of the conductor is 90°C.
2. The current ratings given above are based on an ambient air temperature of 45°C.
3. The current ratings given above are for 6 cables of less bunched or laid together in flat formation. When more than 6 cables are bunched or laid close together, the current ratings given above should be multiplied by correction factor 0.85.
4. For cables with more than four core cables, the current ratings are calculated by the following formula.

$$I = I_1 / N^{1/3}$$

$I_1$ : Current for single core cable

N: Number of cores



### 5. Correction factors for various ambient air temperature

Maximum conductor temperature °C	Correction factors for ambient air temperature									
	35	40	45	50	55	60	65	70	75	80
90	1.10	1.05	1.00	0.94	0.88	0.82	0.74	0.67	0.58	0.47

## Short Circuit Current Ratings

The short circuit currents quoted here are for cables operating normally at maximum conductor temperature of 90°C.

XLPE insulation is actually capable of withstanding short-term temperature up to 250°C.

According to ICEA P-32-382 Curves based on formula:

$$I = A \times \sqrt{\frac{0.115 \log \left( \frac{T_2 + 234}{T_1 + 234} \right)}{t}}$$

I: Short circuit current (kA)

A: Conductor area (mm<sup>2</sup>)

T<sub>1</sub>: Operating temperature (85°C)

T<sub>2</sub>: Short circuit temperature (250°C)

t: Short circuit duration (sec)

**T1 = 90, T2 = 250**

Nominal Area (mm <sup>2</sup> )	Short Circuit Current(kA)													
	Duration of Short Circuit in Second													
	0.03	0.05	0.07	0.1	0.14	0.2	0.3	0.4	0.5	0.6	0.7	0.8	0.9	1.0
1.5	1.26	0.98	0.83	0.69	0.58	0.49	0.40	0.35	0.31	0.28	0.26	0.24	0.23	0.22
2.5	2.02	1.56	1.32	1.10	0.93	0.78	0.64	0.55	0.49	0.45	0.42	0.39	0.37	0.35
4	3.25	2.52	2.13	1.78	1.50	1.26	1.03	0.89	0.80	0.73	0.67	0.63	0.59	0.56
6	4.86	3.77	3.18	2.66	2.25	1.88	1.54	1.33	1.19	1.09	1.01	0.94	0.89	0.84
10	8.19	6.34	5.36	4.49	3.79	3.17	2.59	2.24	2.01	1.83	1.70	1.59	1.50	1.42
16	12.99	10.06	8.50	7.11	6.01	5.03	4.11	3.56	3.18	2.90	2.69	2.52	2.37	2.25
25	20.6	15.9	13.5	11.3	9.5	8.0	6.5	5.6	5.0	4.6	4.3	4.0	3.8	3.6
35	28.5	22.1	18.7	15.6	13.2	11.1	9.0	7.8	7.0	6.4	5.9	5.5	5.2	4.9
50	38.6	29.9	25.3	21.2	17.9	15.0	12.2	10.6	9.5	8.6	8.0	7.5	7.1	6.7
70	55.9	43.3	36.6	30.6	25.9	21.6	17.7	15.3	13.7	12.5	11.6	10.8	10.2	9.7
95	77.5	60.0	50.7	42.4	35.9	30.0	24.5	21.2	19.0	17.3	16.0	15.0	14.1	13.4
120	97.9	75.8	64.1	53.6	45.3	37.9	31.0	26.8	24.0	21.9	20.3	19.0	17.9	17.0
150	120.3	93.1	78.7	65.9	55.7	46.6	38.0	32.9	29.5	26.9	24.9	23.3	22.0	20.8
185	150.8	116.8	98.8	82.6	69.8	58.4	47.7	41.3	36.9	33.7	31.2	29.2	27.5	26.1





## Technical Information

www.caledonian-cables.co.uk

Nominal Area	Short Circuit Current(kA)													
	Duration of Short Circuit in Second													
240	198.3	153.6	129.8	108.6	91.8	76.8	62.7	54.3	48.6	44.3	41.0	38.4	36.2	34.3
300	248.7	192.6	162.8	136.2	115.1	96.3	78.6	68.1	60.9	55.6	51.5	48.2	45.4	43.1
400	329.3	255.1	215.6	180.4	152.5	127.6	104.1	90.2	80.7	73.6	68.2	63.8	60.1	57.0
500	401.0	310.6	262.5	219.6	185.6	155.3	126.8	109.8	98.2	89.7	83.0	77.7	73.2	69.5

## Reactance / Impedance

### Reactance

Conductor area(mm <sup>2</sup> ) Rating	1.5	2.5	4	6	10	25	35	50	70	95	120	150	185	240	300
Reactance factors (Ω /km)	0.135	0.125	0.117	0.111	0.103	0.098	0.097	0.094	0.091	0.090	0.088	0.088	0.088	0.088	0.087

The reactance of a cable operating in AC system depends on many factors, including, in particular, the axial spacing between conductors and proximity and magnetic properties of adjacent steelwork. The former is known for multicore cable, but may vary for single core cables depending upon the spacing between them and their disposition when installed.

Reactances of cables in certain dispositions remote from steelwork are calculable and are shown. The tabulated values are for cables with circular conductors. The value for a sector-shaped conductor should be taken as 90% of the tabulated value. The value of reactance so calculated is for a supply frequency of 60Hz. For any other frequency, a correction should be made in direct proportion to the frequency.

For example at 50Hz, the reactance is 0.83 times that at 60Hz. Induction for 2-and 3-conductor cables is given by the formula:

$$L = 0.2 \times [\ln(2a/b) + 0.25] \times 10^{-6}$$

L = Inductance in H/m and phase

a = Axial space between conductor

d = Conductor diameter in mm

Reactance for 2-and 3-conductor cables is given by the formula:

$$X = 2 \times \pi \times f \times L \times I$$

X = Reactance in ohm per phase

f = Frequency in Hz

L = Inductance in H/m and phase

I = Conductor length in meter





### Impedance

Conductor area (mm <sup>2</sup> )	1.5	2.5	4	6	10	16	25	35	50	70	95	120	150	185	240	300
Rating factors (Ω /km)	15.557	9.641	5.994	3.967	2.348	1.482	0.941	0.681	0.507	0.356	0.265	0.215	0.183	0.155	0.131	0.116

Impedance for 2, 3 & 4 conductor cables is given by the formula:

$$Z = \sqrt{(R^2 + X^2)}$$

Z = Impedance in ohm per phase

R = Resistance at operating temp. in ohm per phase

X = Reactance in ohm per phase

### Voltage Drop (Cables Up to 1 KV)

Nominal c.s.a mm <sup>2</sup>	K					
	3x1 cores (trefoil formation)		2 cores		3-4 cores	
	C.d.T. c.a. cosfi 1 mV/Am	C.d.T. c.a. cosfi 0.8 mV/Am	C.d.T. c.a. cosfi 1 mV/Am	C.d.T. c.a. cosfi 0.8 mV/Am	C.d.T. c.a. cosfi 1 mV/Am	C.d.T. c.a. cosfi 0.8 mV/Am
1			46.4	37.3	40.1	32.3
1.5			31.1	25.0	26.9	21.7
2.5			19.3	15.6	16.7	13.5
4			12.0	9.73	10.4	8.41
6			7.93	6.48	6.860	5.60
10	3.51	2.90	4.69	3.88	4.059	3.35
16	2.21	1.86	2.96	2.48	2.559	2.15
25	1.40	1.21	1.87	1.61	1.620	1.39
35	1.01	0.891	1.35	1.19	1.168	1.03
50	0.747	0.681	0.998	0.910	0.864	0.787
70	0.517	0.494	0.690	0.660	0.597	0.571
95	0.374	0.379	0.500	0.507	0.432	0.439
120	0.296	0.316	0.396	0.422	0.343	0.365
150	0.244			0.273	0.282	0.316
185	0.195			0.234	0.225	0.271
240	0.151			0.198	0.174	0.229
300	0.122			0.175	0.142	0.203



### Voltage Drop Coefficient

The voltage drop coefficients in each circuit are given in the following table

Voltage	Conductor size mm <sup>2</sup>	Voltage drop coefficient						
		100	95	90	85	80	75	70
250V	0.75	1.00	0.95	0.90	0.85	0.80	0.75	0.70
	1	1.00	0.95	0.90	0.85	0.80	0.75	0.70
0.6/1KV	1.5	1.00	0.95	0.90	0.85	0.80	0.75	0.71
	2.5	1.00	0.95	0.90	0.86	0.81	0.76	0.71
	4	1.00	0.96	0.91	0.86	0.81	0.76	0.71
	6	1.00	0.96	0.91	0.86	0.81	0.77	0.72
	10	1.00	0.96	0.92	0.87	0.82	0.77	0.73
	16	1.00	0.97	0.92	0.88	0.83	0.76	0.74
	25	1.00	0.98	0.94	0.90	0.85	0.81	0.76
	35	1.00	0.99	0.95	0.91	0.87	0.83	0.78
	50	1.00	1.00	0.97	0.93	0.89	0.85	0.81
	70	1.00	1.02	1.00	0.97	0.93	0.90	0.86
	95	1.00	1.04	1.03	1.01	0.98	0.95	0.92
	120	1.00	1.07	1.06	1.05	1.03	1.00	0.97
	150	1.00	1.09	1.10	1.09	1.08	1.05	1.03
	185	1.00	1.13	1.15	1.15	1.15	1.13	1.11
	240	1.00	1.19	1.23	1.25	1.25	1.25	1.24
300	1.00	1.24	1.31	1.35	1.36	1.37	1.37	

